

OEM REPLACEMENT MOTOR "For Krack"



**INCLUDES
QUICK CONNECT
OEM PLUG**



Features For Both:

- Direct OEM Replacements:
No Modifications Required
- Shaded Pole
- Sleeve Bearing
- Thermally Protected
- 40°C Ambient
- Single Phase
- 50/60 Hertz
- Insulation Class B
- Enclosed
- Lug Mount
- Lead and Plug Assembly
- UL and CSA Approved
- See Reverse Side for Outline Drawing

Stock No. 9627
Krack No. 11528 (115V)

Replacement for:
Century JA2P216
Emerson 9654 (115/230V)
Fasco 8254111030
Fasco D1189 (115/230V)
Krack 11528

Stock No. 9628
Krack No. 11529 (200-230V)

Replacement for:
Century JA2P217
Century JA2S149
Emerson 9654 (115/230V)
Fasco 8254160210
Fasco D1189 (115/230V)
Krack 11529

Stock No.	HP	Volts	Amps	RPM	Speeds	Frame	HZ	Rotation	Wt.
9627	1/25	115	1.5/1.3	1250/1550	1	3.3	50/60	CWSE	4.5
9628	1/20	200-230	0.90	1550	1	3.3	50/60	CWSE	5.5

NOW AVAILABLE!
FAX OR PHONE YOUR ORDER TODAY!



Universal Electric Motors
6200 Dixie Road, Unit 1
Mississauga, Ontario, L5T 2E1
Tel: (905) 670-3380
Toll Free: 1-877-670-3380
Fax: (905) 670-7637 www.uem.ca

A Regal Brand

REGAL

OEM REPLACEMENT FOR KRACK

STOCK NO. 9627

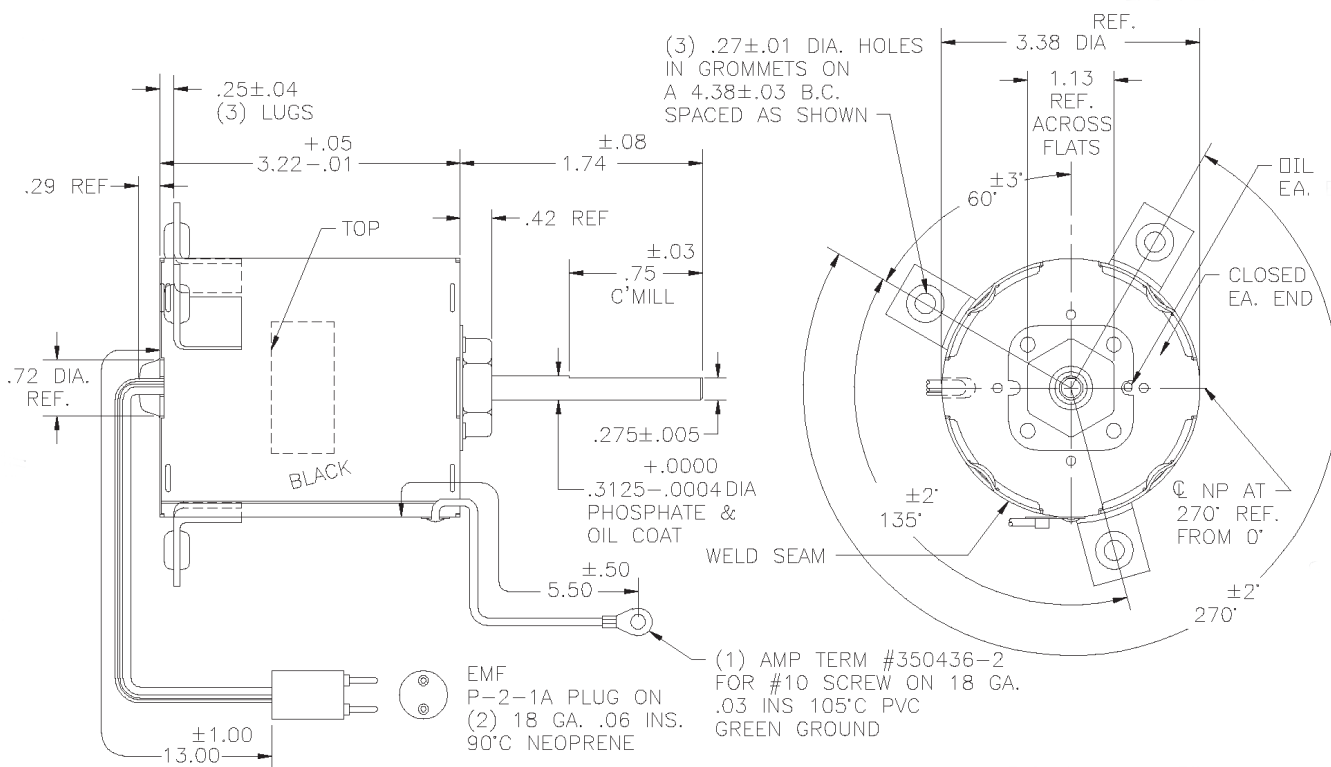

OEM REPLACEMENT FOR KRACK

STOCK NO. 9628

